

# LIJMEN IN DE BAGGER

---

ARJAN TANIS

---

---

MID 4 NOVEMBER 2013

---





# SAFETY STATEMENT

Our people are our most valuable assets, making safety a core value. Our goal is: No Injuries No Accidents. This is embedded in our company's culture and supported through Values and Rules. All employees, including our sub-contractors, are expected to take these values and rules to heart.

## VALUES

- I AM RESPONSIBLE FOR MY OWN SAFETY**
- I APPROACH OTHERS ABOUT WORKING SAFELY**
- I TAKE ACTION IN CASE OF UNSAFE OPERATIONS  
IF NECESSARY, I WILL STOP THE WORK**
- I ACCEPT FEEDBACK ABOUT MY SAFETY  
BEHAVIOUR REGARDLESS OF RANK AND  
POSITION**
- I REPORT ALL INCIDENTS, INCLUDING  
NEAR-MISSES, TO INFORM OTHERS AND BUILD  
ON LESSONS LEARNED**

## RULES

- PREPARE A RISK ASSESSMENT FOR EACH  
PROJECT, VESSEL OR LOCATION**
- OBTAIN A PERMIT TO WORK FOR DEFINED  
HIGH-RISK ACTIVITIES**
- MAKE A JOB HAZARD ANALYSIS FOR  
HAZARDOUS NON-ROUTINE ACTIVITIES**
- BE INFORMED ABOUT RISK & CONTROL  
MEASURES**
- BE FIT FOR DUTY AND WEAR THE PPE  
REQUIRED**



# INDEX

- 
- |           |                                    |
|-----------|------------------------------------|
| <b>01</b> | <b>LIJMEN VAN BAGGERSCHEPEN</b>    |
| <b>02</b> | <b>WELKE MATERIALEN</b>            |
| <b>03</b> | <b>GEBRUIKSOMSTANDIGHEDEN</b>      |
| <b>04</b> | <b>ONDERDELEN IN BAGGERPOMP</b>    |
| <b>05</b> | <b>LIJMEN VAN KUNSTSTOF PLATEN</b> |
| <b>06</b> | <b>REPARATIE MATERIALEN</b>        |
| <b>07</b> | <b>KUNSTSTOF LAGERBUSSEN</b>       |
| <b>08</b> | <b>KUNSTSTOF GELEIDINGEN</b>       |
| <b>09</b> | <b>GRE LEDINGEN</b>                |
| <b>10</b> | <b>CONCLUSIE</b>                   |
-



# LIJMEN VAN BAGGERSCHEPEN



# LIJMEN IN DE BAGGER

## MATERIALEN

- Staal aan staal
- Kunststoffen aan staal
- Kunststoffen aan elkaar
- Rubbers

## ALTERNATIEF OF AANVULLEND

- Lassen
- Boutverbinding
- Krimpverbinding





# KLIMAAT



# KLIMAAT





# KLIMAAT





# WERKOMGEVING

MOET SCHOON ZIJN



# VOORBEELD BAGGERPOMP

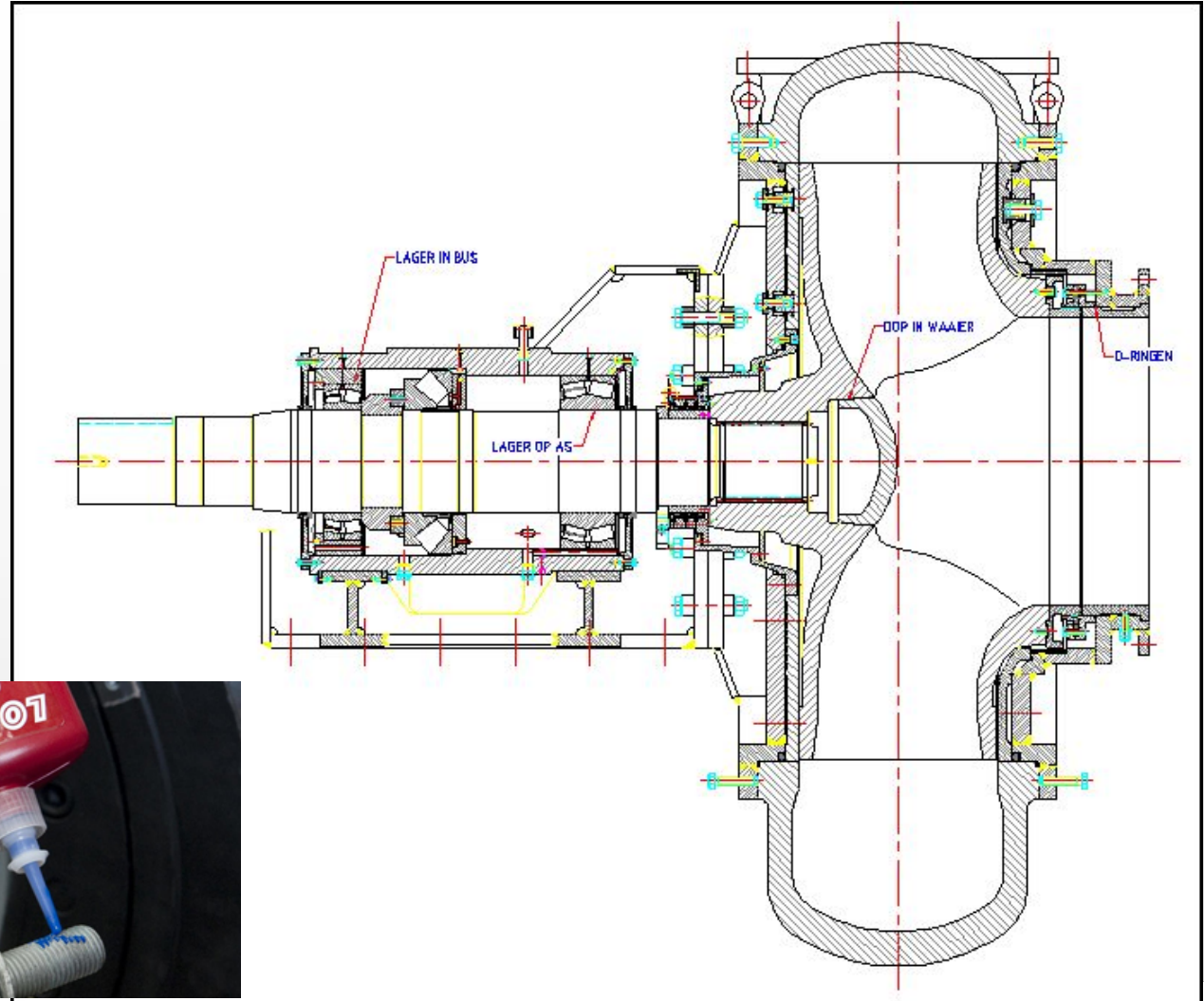



# PLATEN POLYURETHAAN IN HOPPER





# REPARATIEMATERIALEN

**HECHTING OP WIT GIETIJZER  
ZOALS NIHARD 4, MAX 5 OF  
MOHARD IS MINIMAAL VANWEGE  
VRIJE KOOLSTOF IN STRUCTUUR**





# REPARATIEMATERIALEN

**OP STAAL IS HECHTING WEL  
MOGELIJK**





# KUNSTSTOF LAGERBUSSEN EN SCHALEN

**LIJMEN, EVENTUEEL IN COMBINATIE MET KRIMP OF PERSPASSING  
VOOR CORROSIE BESCHERMING EN OVERDRACHT BELASTINGEN**





# PAALWAGEN GELEIDING

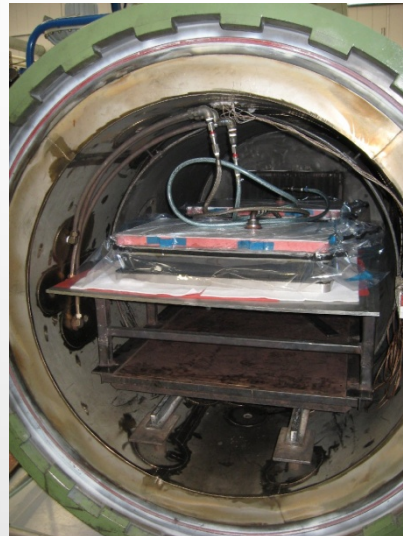
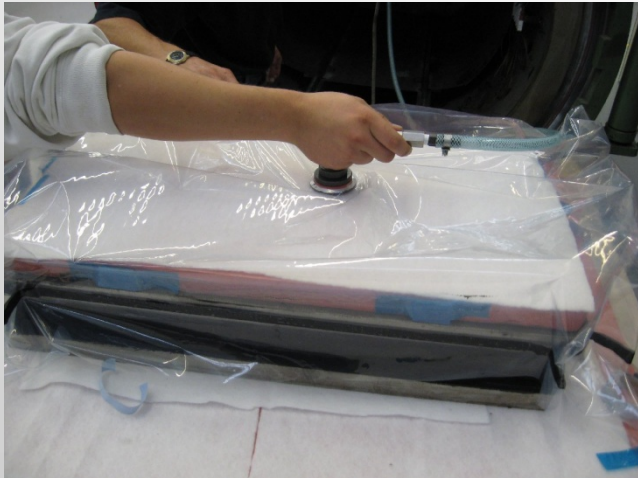
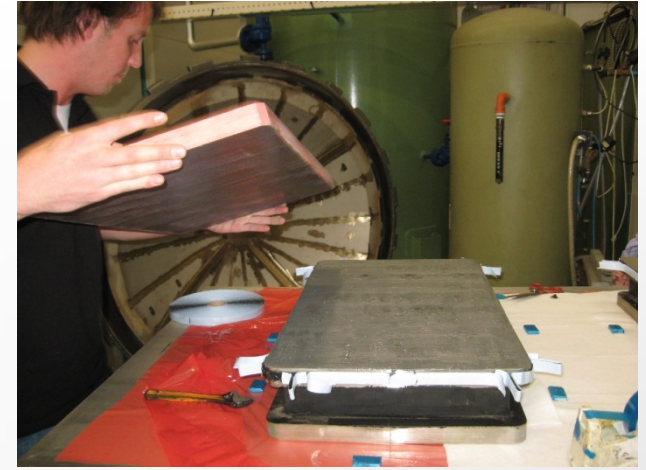

# COMBINATIE LIJMEN EN BOUTEN

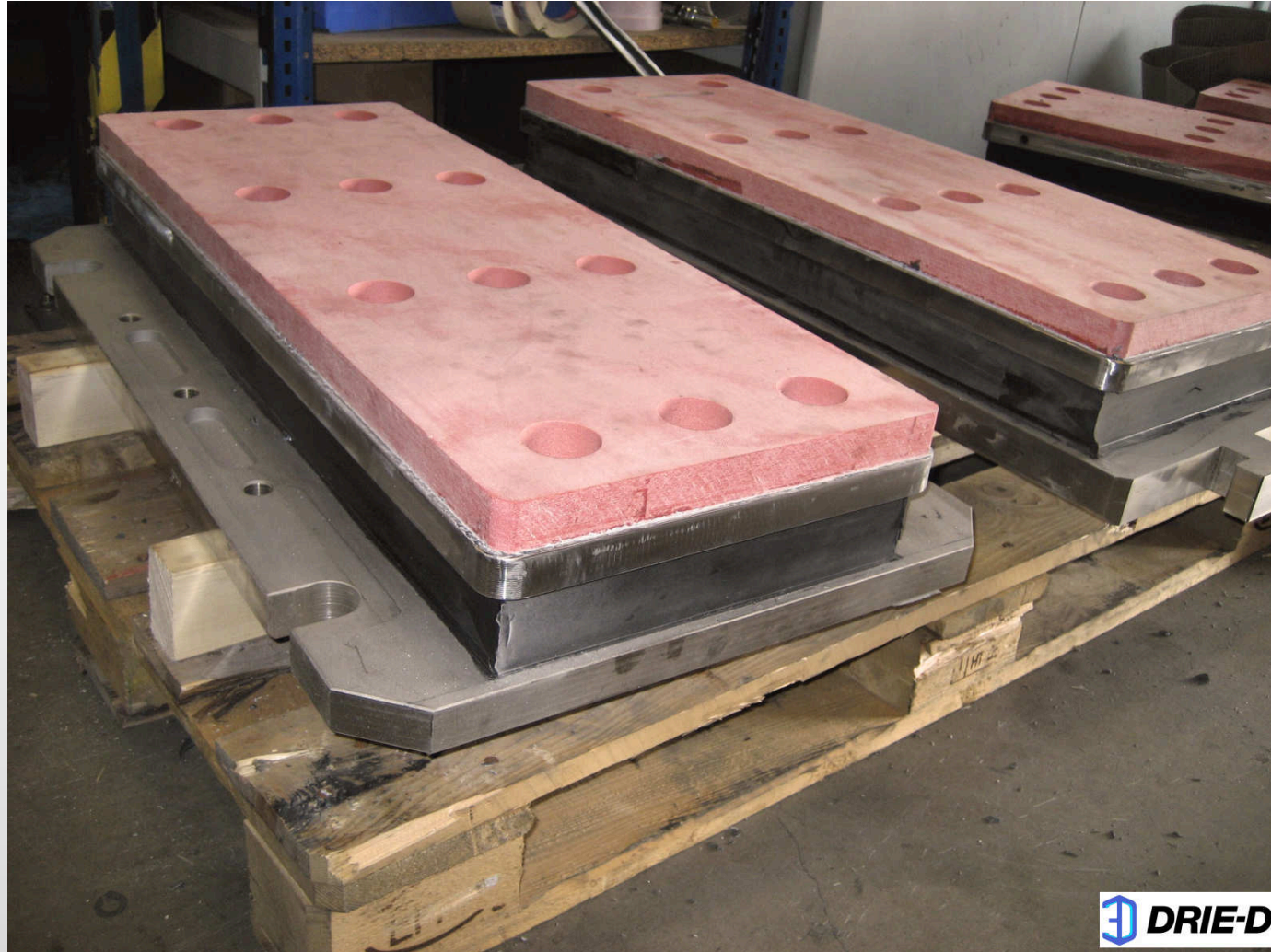



# GRE LEIDINGEN

IS AAN BOORD TE DOEN  
MAAR VEREIST INSTRUCTIE



# CONCLUSIE

- **WORDT AL VELE JAREN VOOR EEN KLEIN AANTAL TOEPASSINGEN GEBRUIKT**
- **MOEILIK IN NAUTISCHE OMGEVING**
- **ONZEKERHEID OVER LEVENSDUUR I.V.M.**
  - **Corrosie van staal**
  - **Temperatuur / veroudering**
- **VRAAGT GROTE ZORGVULDIGHEID EN KENNIS VAN LIJMEN EN PROCEDURE**
- **VEILIGHEID VAN TOEPASSING MOET GEWAARBORGD ZIJN**
- **NIEUWE TOEPASSINGEN?**



# BEDANKT

